

MISSIONFEST TORONTO

April 12 – 14, 2012

EXHIBITOR'S POLICIES MANUAL 2012



Contact:
MissionFest Toronto
1.905.839.5053 or 866.780.9157
exhibitors@missionfest.org

Table of Contents

MFT GENERAL CONTACT INFORMATION	2-3
EXHIBIT HALL INFORMATION	4-9
BOOTH ACCESSORIES	4
BOOTH SUBLETTING AND SHARING	4
CANCELLATION BY EXHIBITOR	4
CANCELLATION BY EVENT MANAGEMENT	4
DISPLAY RULES AND REGULATIONS	4-5,10-13
DISTRIBUTION OF MATERIALS	5
DRAWS	5
ELECTRICAL	5
ENTRY TO THE EVENT	5
EXHIBITOR ONSITE INFORMATION CENTRES	5
EVENT MANAGEMENT	5
FLOOR PLANS	6
FREE SERVICES BY EVENT MANAGEMENT	6
HAND-CARRIED MATERIAL	6
HOTEL DISCOUNTS	6
INSPECTION DEADLINE	6
INSURANCE	6
INTERNET	7
LOSS OR DAMAGE	7
MEETINGS IN YOUR BOOTH	7
MOVE-IN AND SET UP	7
MOVE-OUT AND TEAR DOWN	8
NON-COMPLIANCE WITH MFT POLICIES	8
OBJECTIONABLE CONDUCT	8
PAYMENT OF EXHIBIT SPACE	8
RE-ASSIGNMENT OF SPACE	8
REMOVAL OF EXHIBIT	9
SALES	9
SOUND LEVELS	9
STATEMENT OF FAITH	9
STAFFING OF EXHIBITS	9
SET-UP IDEAS FOR 4'x6' and 4'x8' BOOTHS	14

N.B.: All forms and applications will be made available on the MFT website, www.missionfest.org. Please ensure all forms and applications are signed and that you are in agreement with the Exhibitor's Policies Manual.

MFT General Contact Information

AUDIO VISUAL:

APEX Sound and Lighting
7 – 1750 Plummer Street
Pickering, Ontario L1W 3L7
Tel: 905.831.2739
Fax: 905.831.5382
E-mail: apex@apexsound.com

EVENT MANAGEMENT:

MissionFest Toronto (MFT)
1730 McPherson Court, Unit 1
Pickering, Ontario L1W 3E6
Tel: 905.839.5053 or 866.780.9157
Fax: 905.839.0467
E-mail: info@missionfest.org

EXHIBITOR SERVICES:

Robinson Show Services Inc.
30 Klamath Court
Maple, Ontario L6A 2L7
Tel: 905.417.7789

www.robinsonshowservices.ca

FACILITY:

Global Kingdom Ministries (GKM)
1250 Markham Road
Scarborough, ON
Tel: 416.438.1601
www.globalkingdom.ca

HOTEL INFORMATION:

Best Western Executive Inn
38 Estate Drive
Scarborough, ON M1H 2Z1
Tel. 416-430-0444
See www.missionfest.org under *Accommodations* for more information.

EVENT INSURANCE PROVIDER:

JD Smith & Associates
2 –105 West Beaver Creek Road
Richmond Hill, Ontario L4B 1C7
Tel: 905.764.7868 or 800.917.7283
Fax: 905.764.9618
E-mail: doris@jdsfinancial.ca
Contact: Doris Chaykowsky, x206

INTERNET:

MissionFest Toronto (MFT)
1730 McPherson Court, Unit 1
Pickering, Ontario L1W 3E6
Tel: 905.839.5053 or 866.780.9157
Fax: 905.839.0467
E-mail: exhibitors@missionfest.org

Exhibit Hall Information

BOOTH ACCESSORIES:

The Event Management's Exhibitor Service Contractor, Event Show Services, provides all booth accessories. Advance discount pricing is available when you submit your application promptly before **February 28, 2012**. Please be sure to indicate your booth number on all forms. **N.B.** *You are allowed to bring your own accessories (tables, chairs, carpet, displays) providing you maintain the integrity of the exhibit floor. Carpet will not be allowed in the Atrium or Gym Foyer.* Your accessories should be ordered through MFT prior to the event. Please see [Exhibitor Space Application](#) and [Exhibitor Rate Schedule & Policies Form](#) as available on the MFT website, www.missionfest.org

BOOTH SUBLETTING AND SHARING:

It is agreed that under no circumstances shall space be sublet to another organization. Exhibit sharing by two organizations will not be allowed, as the new venue booth sizes do not permit room for sharing.

CANCELLATION BY EXHIBITOR:

Exhibitor will receive refund in the amount of booth space rental (less \$75.00), if written notice is received by **December 31st, 2011**. No refunds after December 31st, 2011 for cancellations or no-shows to the event.

CANCELLATION BY EVENT MANAGEMENT:

Event Management reserves the right to cancel space should payment not be received from the exhibitor within the prescribed time frame. If Event Management should be prevented from holding the show by any cause beyond its control, or if it cannot permit the exhibitor to occupy his/her rented space due to circumstances beyond its control, including but not limited to, strike, fire, civil disobedience, inclement weather, lockout, and acts of God, Event Management assumes no responsibility for loss or damage incurred, and Event Management shall have no further obligation or liability to the exhibitor.

DISPLAY RULES AND REGULATIONS:

The following rules and guidelines specify what an exhibitor can and cannot do with his/her booth space. These rules and guidelines are based on the physical characteristics of the Exhibit Space, the intent to be equally fair to all exhibitors, and the safety of all concerned.

Please review these rules and plan your display accordingly as variances will not be granted prior to the show or on-site. (pages 10-13)

Presentation in Your Booth:

Presentations must be confined within the exhibit space so as not to interfere with any traffic in the aisles. Exhibit Booths must have sufficient space to be able to comply with this rule. Aisles may not be obstructed at any time. Based on the size of your exhibit space, please ensure that the appropriate amount of set-material is allotted.

Please note that **ALL FIRE HOSE CABINETS MUST BE KEPT VISIBLE AND CLEAR.**

Signage:

The following maximum height limits will be strictly enforced. No height variances will be granted prior to or on site at the event. Please plan your booth display and sign structures accordingly.

All Regular Booths 8' (ft) high (located in Atrium, Gym Foyer and Exhibit Hall)
Table Top Hallway Spaces (restricted to what can only sit on the table)
Canopies & False Ceilings (see page 12)

Please see MissionFest Toronto's [Display Rules and Regulations](#) on page 10 for specific instructions.

N.B. Nothing will be permitted above these maximum heights, including signs, banners, and display materials.

DISTRIBUTION OF MATERIALS:

Display, presentations and distribution of advertising material are not permitted outside of your booth space.

N.B. Events Management reserves the right to withdraw any advertising material that does not adhere to the core values and objectives of MFT.

DRAWS:

Draws conducted by exhibitors in conjunction with their display must be free of any obligation on the part of the winner. Prize winners must not be required to place an order before collecting the prize offered. The schedule of prizes and terms of the draw must be clearly stated on the entry form.

ELECTRICAL:

Electrical power is **ONLY** available to the booths that are pre-assigned as per the rates and policies schedule.

ENTRY TO THE EVENT:

Event Management reserves the right to refuse admission to the event building to any visitor, exhibitor or contractor who, in the opinion of Event Management, is unfit, intoxicated, or in any way creating a disruption of the conference.

N.B. For security reasons, we ask that you wear your Exhibitor Badge in a prominent location while on the exhibit floor.

EXHIBITOR ONSITE INFORMATION CENTRES:

MFT's Exhibitor Info Centre will be open for all inquiries regarding booth services and orders including booth accessories, utilities, and special event services. *Located in the Gym Foyer.*

Show Services provider will maintain a Service Centre during set-up on the first day of the event in the Exhibit Hall in the Gym Foyer.

EVENT MANAGEMENT:

Throughout the entire event period, Event Management (MissionFest Toronto) can be contacted onsite at Main Info Centre in Church Atrium and at Exhibitor Info Centre in Gym Foyer.

FLOOR PLANS:

Please refer to the MFT website, www.missionfest.org for full Conference floor plan and Exhibit Space plans.

FREE SERVICES BY EVENT MANAGEMENT:

- Organization listing in the 'Program Magazine' and on MFT website (*December 31st, 2011 deadline*)
- Exhibitor Badges (2 only per organization)
- Publicity and Promotion
- Aisle cleaning
- Dollies for move-in and move-out

HAND-CARRIED MATERIAL:

If you **require** assistance to move in/out your materials to/from the event, the following has been set up for your convenience.

- Dollies & Volunteers will be available at the loading areas. *This is a first come first serve basis and you may have lag time before one becomes available, please remain patient.*
- Unload your vehicle as quickly as possible. Volunteers are available to help and will remain with the dollies at all times.

HOTEL DISCOUNTS:

See www.missionfest.org under *Accommodations* for more information.

INSPECTION DEADLINE:

Any booth not occupied by Thursday, April 12th at 6:00pm. will be presumed abandoned, unless otherwise notified. If there is no content in the booth and/or Event Management believes the Exhibitor will not participate in the event, the booth will be reassigned. Exhibitors arriving after this time will be given space based on availability and may incur disciplinary action.

INSURANCE:

Exhibitors are responsible to carry their own liability insurance with a **minimum of \$2 million** coverage for the duration of their involvement with the event to include theft, public liability, property damage, and exhibitor's personnel, exhibits and materials.

Event Management and its contractors will not be responsible for injury or damage that may occur to an attendee, exhibitor or his/her employees or agents, nor to the safety of any exhibit or other property against theft, fire, accident, or any other destructive causes.

INTERNET:

All Internet requests will be handled through the Event Management – (MissionFest Toronto) in care of the facility. Please contact: MissionFest Toronto Office Directly.

LOSS OR DAMAGE:

Exhibitors will be liable for, and will indemnify and hold harmless MissionFest Toronto, its officers, employees, agents and affiliates from, any loss or damage whatsoever occurring to or suffered by any person or organization, including, without limiting the generality of the foregoing, exhibitor, other exhibitors, management, the owners of the building and their respective agents, servants and employees, and members of the public attending the show, either (a) on the said space or (b) elsewhere. Neither the Facility nor Event Management will be responsible for loss or damage to persons, exhibits belongings, or decorations by fire, accident, theft, or any cause while in the exhibition buildings, and or property as well as personal injuries or death.

MEETINGS IN YOUR BOOTH:

If you plan to use your booth to conduct meetings **before or after official show hours**, you must email the following information to the Exhibitor Coordinator of MFT at exhibitors@missionfest.org.

1. A letter requesting early access to the exhibit space. Please state the exhibiting organization and booth location.
2. State the time and date of the meeting (meetings cannot be scheduled prior to the show opening on April 12th).
3. State the names of the exhibitor and guest(s) attending the meeting, and escort them directly to the booth.
4. Access to the floor during non-show hours will be denied unless Event Management receives this written request in advance.

MOVE-IN AND SET UP:

The installation of exhibits will take place during the following schedule:

Thursday, April 12, 2012 from 12:00 noon – 3:00pm. (All Exhibitors, as per move-in scheduled time)
Load in area hours: 12:00 noon – 3:00pm. only. (Location – Front Entrance of GKM and Gym)

Please check in at the Exhibitor Info Centre in the Gym Foyer as per move-in scheduled time.

All booths must be set up by 6:00 p.m., Thursday, April 12th. Absolutely no dollies will be permitted in the exhibit area after that time. Exhibitors who need access to the load in areas and / or dollies will be served on a first-come, first-serve basis.

N.B. - If you arrive before 12:00 noon you will not be permitted to enter the venue.

Exhibitor orientation is on Thursday April 12th, 2012 at 3:30 p.m.

If on-site registration is not complete and display is not in place by 6:00 p.m. Thursday April 12th, MFT reserves the right to use the vacant space as needed.

Exhibit Space Hours of Operation:

Thursday, April 12th, 2012 **6:00 p.m. - 9:00 p.m.**
Friday, April 13th, 2012 **9:00 a.m. - 9:00 p.m.**
Saturday, April 14th, 2012 **9:00 a.m. - 9:00 p.m.**

** Booths are not to be left unstaffed and are to have someone present during Exhibit Space hours of operation.*

MOVE-OUT AND TEAR DOWN:

Saturday, April 14, 2012, 9:00 p.m. – midnight.

In accordance with the exhibitor policies, no exhibits or displays may be dismantled before the official close of the show on Saturday, April 14th, 2012 at 9:00 p.m. Any organization and/or persons found dismantling their booth before this time will result in a fine of \$75 and be reviewed for dismissal from future MFT events. No dollies will be permitted while public are on the Exhibit floors.

All exhibits MUST be removed by midnight on Saturday, April 14th, 2012. At the close of the show, where exhibitors fail to pick up, or couriers refuse to accept shipments, all items will become the property of MFT and will be at the discretion of MFT.

N.B. - In accordance with the exhibitor terms and conditions and security measures, no one under the age of 16 will be admitted in the exhibit spaces at any time during set up or tear down, including infants. There will be no exceptions.

NON-COMPLIANCE WITH MFT POLICIES:

Event Management reserves the right to make changes, amendments, and additions to the policies without notice, as considered necessary to the efficient and proper conduct of the event. Interpretation of these policies shall rest with Event Management and non-compliance can result in the ejection of the offending exhibitor or in the closing of his exhibit space. **Not adhering to the policies of this manual will result in review for dismissal from future MFT Events . Permission to return as an exhibitor will be determined in a review process by the board of directors.* Please also refer to *Exhibitor Rate Schedule and Policies* document.

OBJECTIONABLE CONDUCT:

Event Management reserves the right at any time to reject, prohibit, or remove exhibits or any part thereof, and to expel exhibitors generally from exhibits or the operation of exhibits, which may be objectionable to the participants and management. Without limiting the generality of the foregoing, this paragraph applies to a person's conduct or any printed matter, which may affect the integrity of the event.

PAYMENT OF EXHIBIT SPACE:

Full payment of exhibit space, as contracted, must be made within **two (2) weeks of receipt of your application** in order to book desired booth location. Booth space is allocated on a first come first serve basis, postmarks to be observed. Event Management reserves the right to refuse the use of space to any exhibitor who has not made full and final payment. Payment may be made either by cheque or credit card (Visa/MC). Users of credit cards must add 3.5% to cover credit card service charges.

Please see *Exhibitor Space Application* available on the MFT website, www.missionfest.org.

RE-ASSIGNMENT OF SPACE:

Event Management shall have the right to change, if necessary, the assignment of space to be occupied by the exhibitor in order to create an effective/presentable exhibit space area.

REMOVAL OF EXHIBIT:

The exhibitor further agrees that the terms, conditions, rules and regulations of MissionFest Toronto (Event Management) are made a part of this contract and that said exhibitor agrees to be bound by each and all of these rules and regulations, and that Event Management shall have the full power to interpret, amend, and enforce all rules and regulations in the best interest of the event.

SALES:

Materials and Products sold by an Exhibitor should be produced by the primary ministry the Exhibitor represents, with a focus on 'ministry' and 'missions'. If your ministry does not author/publish or produce the materials and products being sold, you are required to submit a product title list to MFT no later than 30 days prior to event for approval.

MissionFest Toronto requires a 10% commission on all gross sales prior to sales tax.

Event Management has allocated ten (10%) percent of the floor for ministries with sales and reserves the right to refuse space for this purpose or to close such exhibits without liability. All exhibitors with the intention of having sales must notify Event Management 60 days prior to event by submitting MFT *Exhibitor Sales Agreement*. MissionFest Toronto is not a venue for fundraising or ticket/event sales.

All commission remittances should be sent to MissionFest within 30 days following the Conference.

SOUND LEVELS:

Sound level of presentation should be kept within the confines of the booth area and must not interfere with or affect neighbouring exhibits. Event Management will exercise their right to provide and maintain a fair exhibiting environment to all exhibitors. TV's in the exhibit space must have sound **off** at all times; for any type of sound that is part of your display please have headphones available. Voice amplification may be used only with **permission from Event Management prior to event opening.**

STATEMENT OF FAITH:

All exhibitors are required to sign and submit the MissionFest Toronto Statement of Faith. Please see [MFT's Statement of Faith](#) as available on the MFT website, www.missionfest.org.

STAFFING OF EXHIBITS:

Exhibitors must maintain staff in their booths at all times during exhibit hall hours.

Display Rules and Regulations

REGULAR BOOTHS:

Regular booths consist of 4'x6', 4'x8', 8'x8', 8'x10', or 10'x 10' booths located in either of the following exhibit space areas: Atrium, Gym Foyer or Exhibit Hall.

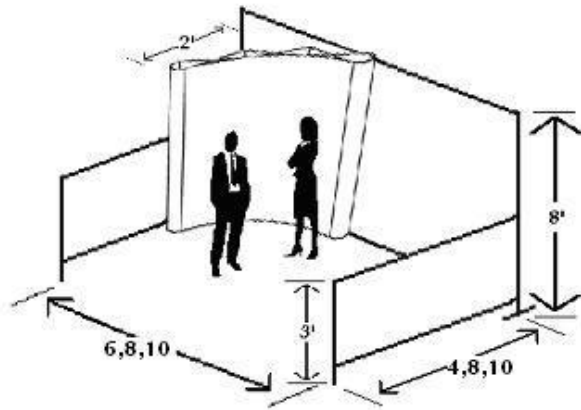

Booth Dimensions:

All booths have a 3' high side pipe and drape with an 8' high backdrop. Booths are either 6', 8', or 10' wide and depth is determined by size acquired.

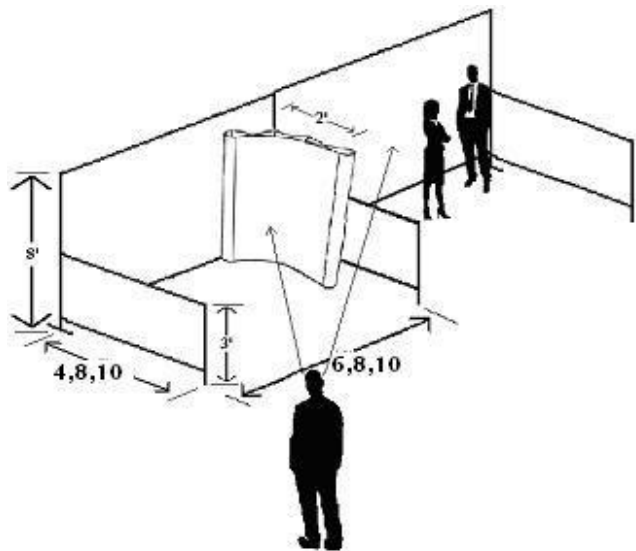

Height

All exhibit signage, displays, apparatus and fixtures will be permitted to be a maximum height of 8', the height of the exhibit backdrop.

Reason

Any element extending past the 8' background distracts on the whole from the exhibit directly behind that given booth, regardless of how attractive the exhibit is furnished.

Depth

All exhibit fixtures are restricted to the exhibit booth space and must not extend into the aisle. Exhibit signage and displays must not protrude beyond 2' from the backdrop of any given booth.

Reason

Each exhibitor is entitled to a reasonable sightline from the aisle regardless of the size of exhibit. Exhibitors are encouraged to effectively use as much of the total floor space as possible as long as they do not impede on the rights of others. These restrictions are expected to achieve this.

TABLE TOP HALL SPACES:

Table Top spaces are located on the east and west hallway wings of the church on the first floor and gym building. Each space is 2'x8' and consists of one free chair and one free 2'x4' (ft) unskirted table that will fit into the said 2'x8'(ft) space. Exhibitor must provide his or her own table covering.

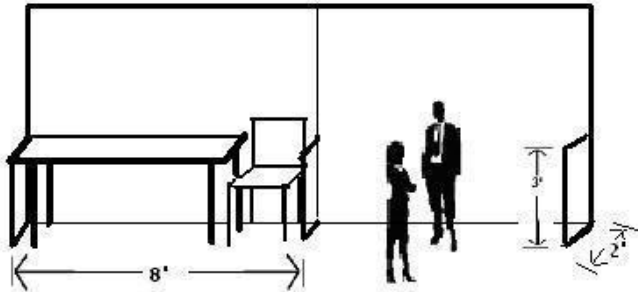

Booth Dimensions:

All Table Top booths are 2'x8' booth space. Each space includes **only** one free unskirted 2'x4' table and one free chair. A pipe and drape rail of 3' will be provided between each tabletop booth where space permits.

Height

All exhibit signage, displays, apparatus and fixtures will be permitted to be displayed only on the top of the table

Reason

There will not be a backdrop, but a 3' side rail will separate all table top booths due to space constrictions. Each table must "butt up to the wall" and are restricted to table top displays only. **No items of any kind are to be taped or attached to the wall in any manner.**

Depth

All exhibit fixtures are restricted to the tabletop hall space and must not extend into the aisle.

Reason

These booths have to "butt up to the wall" and are restricted to table top displays **only**, so not to interfere with traffic in the hallways leading to and from the sessions that will be held during the show.

CANOPIES & FALSE CEILINGS:

An exhibit element supported over an exhibit space for decorative purposes only.

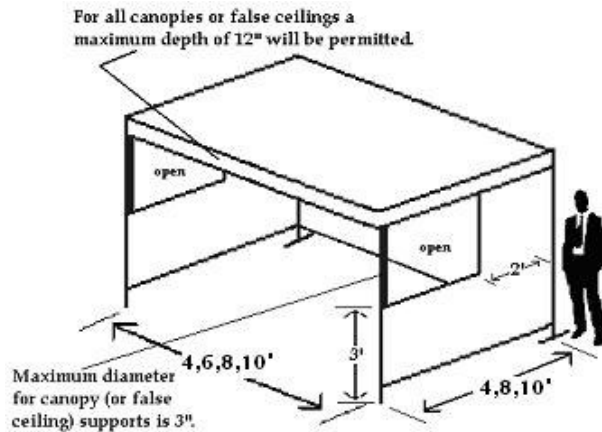

Height

Canopies, false ceilings and umbrellas will be permitted to a height that is compatible with the height regulation for the exhibit space acquired.

Reason

Exhibitors desiring canopies or false ceilings to create the exhibit atmosphere wanted within their booth space should be allowed to do so as long as the canopy and its support system does not violate the purpose of the height or depth regulations.

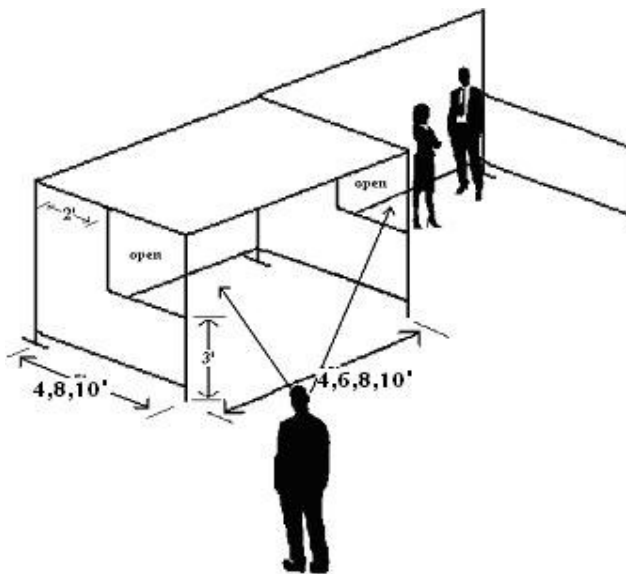

Depth

Canopies may extend out to the aisle line and up to the barriers on either side of the booth space providing that the support structure will not exceed 3" in width.

Reason

Exhibitors next to exhibits with canopies are entitled to the same reasonable sight line from the aisle, as they would anticipate if they were next to an exhibitor with a standard booth.

PRESENTATIONS:

Interactions of exhibit personnel and the attendees through talks, demonstrations or sampling.

Regulation

Presentations must occur within the exhibitor's booth so to not interfere with any traffic; all accessories must be placed a minimum of 2' from the aisle line. Should attendees interfere with the normal traffic flow of the aisle or overflow into neighbouring exhibits, Event Management will have no option but to request that the presentation conclude.

Reason

The aisles are the property of the entire event and each exhibitor has the responsibility to assure proper flow of traffic through the entire hall. When large groups assemble to watch a presentation and prohibit the flow of traffic or collect in neighbouring booths, it is an infringement on the right of other exhibitors. Aisles must not be obstructed at any time.

Sound

*Exhibitors must regulate their own booths to be sure the noise levels from presentations or sound systems is kept to a minimum and does not interfere with others. Remember the use of sound systems or equipment producing sound is an exception to the rule, not a right. Event Management reserves the right to decide at what point sound constitutes interference with others and must be discontinued. TV's in the exhibit space must have sound **off** at all times; for any type of sound that is part of your display please have headphones available.*

Safety Precautions

Exhibitor personnel must stop their presentation in the event of an emergency. All presentations involving potential hazards must be approved in writing by Event Management no less than 60 days prior to the event

SET UP IDEAS FOR 4'x6' and 4'x8' BOOTHS

4'x6' booth

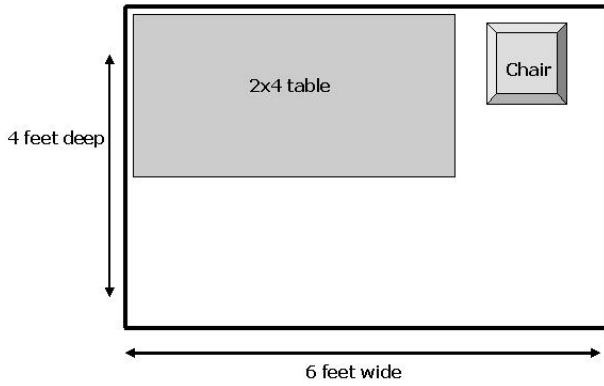

4'x 6' booth

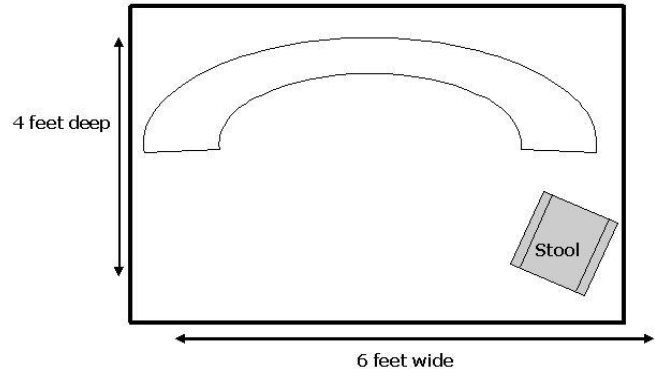

4'x6' booth with a two foot deep by 5-6 foot wide display stand

4'x 8' booth

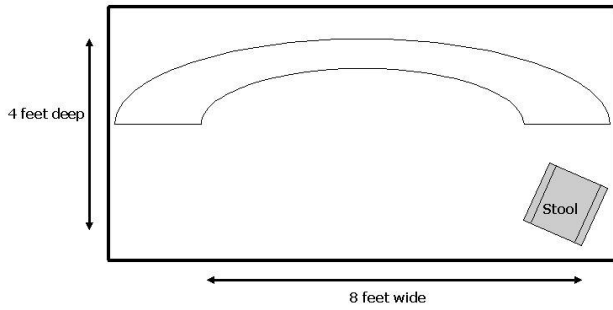

4'x8' booth with a 2'x8' wide display stand

4'x 8' booth

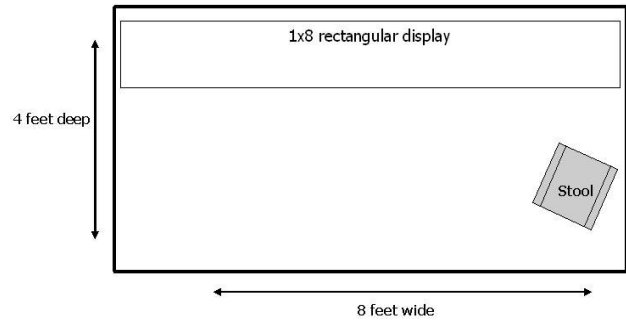

4'x8' Booth with chair and pull up banners

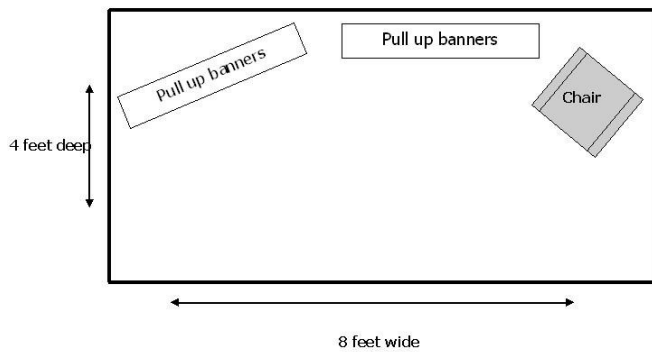

NOTES: